

TECHNICAL BULLETIN

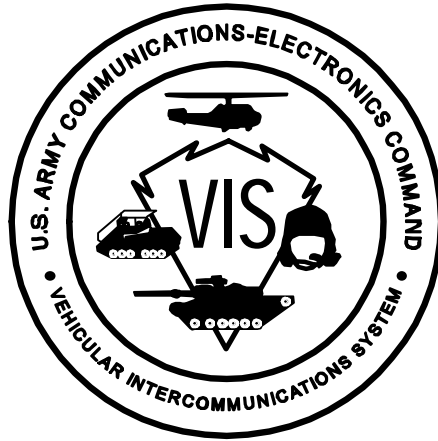

**INSTALLATION INSTRUCTIONS FOR
INTERCOMMUNICATION SET, VEHICULAR
AN/VIC-3(V)17
(NSN 5830-01-460-9327) (EIC: NA)
IN A
GRIZZLY (BREACHER)**

Approved for public release; distribution is unlimited.

DESTRUCTION NOTICE -- Destroy by any method that will prevent disclosure of contents or reconstruction of the document.

HEADQUARTERS, DEPARTMENT OF THE ARMY

1 APRIL 2000

TB 11-5830-263-20-17

LIST OF EFFECTIVE PAGES/WORK PACKAGES

Dates of issue for the original manual and changed pages/work packages are:

Original 1 Apr 00

TOTAL NUMBER OF PAGES FOR FRONT AND REAR MATTER IS 12 AND TOTAL NUMBER OF WORK PACKAGES IS 0, CONSISTING OF THE FOLLOWING:

Page/WP No.	*Change No.	Page/WP No.	*Change No.
Title	0		
Warnings (3 pages)	0		
i thru iv	0		
1 thru 27	0		

* Zero in this column indicates an original page.



5

SAFETY STEPS TO FOLLOW IF SOMEONE IS THE VICTIM OF ELECTRICAL SHOCK

1

DO NOT TRY TO PULL OR GRAB THE INDIVIDUAL

2

IF POSSIBLE, TURN OFF THE ELECTRICAL POWER

3

IF YOU CANNOT TURN OFF THE ELECTRICAL POWER, PULL, PUSH, OR LIFT THE PERSON TO SAFETY USING A DRY WOODEN POLE OR A DRY ROPE OR SOME OTHER INSULATING MATERIAL

4

SEND FOR HELP AS SOON AS POSSIBLE

5

AFTER THE INJURED PERSON IS FREE OF CONTACT WITH THE SOURCE OF ELECTRICAL SHOCK, MOVE THE PERSON A SHORT DISTANCE AWAY AND IMMEDIATELY START ARTIFICIAL RESUSCITATION

WARNING

HIGH VOLTAGE

IS USED IN THE OPERATION OF THIS EQUIPMENT.

DEATH ON CONTACT

MAY RESULT IF PERSONNEL FAIL TO OBSERVE SAFETY PRECAUTIONS.

NEVER WORK ON ELECTRONIC EQUIPMENT UNLESS THERE IS ANOTHER PERSON NEARBY WHO IS FAMILIAR WITH THE OPERATION AND HAZARDS OF THE EQUIPMENT AND WHO IS COMPETENT IN ADMINISTERING FIRST AID. WHEN THE TECHNICIAN IS AIDED BY OPERATORS, HE MUST WARN THEM ABOUT DANGEROUS AREAS.

BE CAREFUL NOT TO CONTACT HIGH-VOLTAGE CONNECTIONS OF THE AC INPUT CONNECTIONS WHEN INSTALLING OR OPERATING THIS EQUIPMENT.

WHENEVER THE NATURE OF THE OPERATION PERMITS, KEEP ONE HAND-AWAY FROM THE EQUIPMENT TO REDUCE THE HAZARD OF CURRENT FLOWING THROUGH VITAL ORGANS OF THE BODY.

WARNING

DO NOT BE MISLED BY THE TERM "LOW VOLTAGE". POTENTIALS AS LOW AS 30 VOLTS MAY CAUSE DEATH UNDER CERTAIN CONDITIONS.

FOR ARTIFICIAL RESPIRATION, REFER TO FM 21-11.

WARNING

WHEN LISTENING TO THE VIS RADIO HEADSET WITH THE OPERATOR VOLUME CONTROLS SETTING IN THE RED ZONE CLICK STOP AT A FULL ON VOLUME SETTING, EXTREME CAUTION MUST BE EXERCISED TO PREVENT NOISE-INDUCED HEARING LOSS. EXPOSURES TO RADIO SIGNALS IN THE FULL ON POSITION BEYOND 45 SECONDS MAY CAUSE HEARING LOSS. ANY PROLONGED EXPOSURE IN THE FULL ON VOLUME CONTROL SETTING REQUIRES THE USE OF A SINGLE HEARING PROTECTIVE DEVICE IN EACH EAR.

WARNING

ALKALINE BATTERIES CONTAIN CAUSTIC KOH ELECTROLYTE, WHICH MAY LEAK IF THE BATTERY IS ABUSED. KOH IS A STRONG ALKALI SIMILAR TO CAUSTIC SODA (SODIUM HYDROXIDE). SERIOUS CHEMICAL BURNS CAN RESULT IF ELECTROLYTE COMES INTO CONTACT WITH THE SKIN OR EYES. IF THE BATTERY ELECTROLYTE GETS INTO YOUR EYES, IT CAN CAUSE SEVERE DAMAGE AND/OR BLINDNESS.

DO NOT TRY TO NEUTRALIZE CAUSTIC ELECTROLYTE WITH VINEGAR OR ANY OTHER ACIDIC SOLUTIONS. NEUTRALIZATION WILL DO MORE HARM THAN GOOD, AS IT WILL TRAP CAUSTIC UNDER THE SKIN, PREVENTING IT FROM COMING OUT. FLUSH WITH COPIOUS AMOUNTS OF COOL WATER.

**INSTALLATION INSTRUCTIONS FOR
INTERCOMMUNICATION SET, VEHICULAR
AN/VIC-3(V)17
(NSN 5830-01-460-9327) (EIC: NA)
IN A
GRIZZLY (BREACHER)**

REPORTING ERRORS AND RECOMMENDING IMPROVEMENTS

You can help improve this manual. If you find any mistakes, or if you know of a way to improve the procedures, please let us know. Mail your letter, DA Form 2028 (Recommended Changes to Publications and Blank Forms) or DA Form 2028-2 located in back of this manual direct to: Commander, US Army Communications-Electronics Command and Fort Monmouth, ATTN: AMSEL-LC-LEO-D-CS-CFO, Fort Monmouth, New Jersey 07703-5007. The fax number is 732-532-1413, DSN 992-1413. You may also e-mail your recommendations to AMSEL-LC-LEO-PUBS-CHG@cecom3.monmouth.army.mil

In either case a reply will be furnished direct to you.

APPROVED FOR PUBLIC RELEASE; DISTRIBUTION IS UNLIMITED.

TABLE OF CONTENTS

SUBJECT	PAGE
SECTION I. INTRODUCTION.....	1
1.1 SCOPE.....	1
1.2 GENERAL INFORMATION.....	1
1.3 CONSOLIDATED INDEX OF ARMY PUBLICATIONS	2
1.4 MAINTENANCE FORMS, RECORDS, AND REPORTS.....	2
1.5 CORROSION PREVENTION AND CONTROL	2
SECTION II. PREPARATION FOR INSTALLATION.....	3
2.1 PREPARING THE VEHICLE	3
2.2 EXPENDABLE/DURABLE ITEMS.....	4
2.3 TOOLS AND TEST, MEASUREMENT AND DIAGNOSTIC EQUIPMENT.....	4
2.4 VIS COMPONENTS (PARTS LIST)	5
2.5 PRE-INSTALLATION STEPS AND PROCEDURES	8

TABLE OF CONTENTS (continued)

SUBJECT	PAGE
SECTION III. FFCS AND RIT CREW STATION/RADIO SWITCH SETTING PROCEDURES	9
3.1 FFCS CREW STATION ADDRESS SWITCH SETTING PROCEDURES	9
3.2 RIT RADIO SELECTION SWITCH SETTING PROCEDURES	9
SECTION IV. INSTALLATION INSTRUCTIONS	10
4.1 EQUIPMENT LOCATION AND SYSTEM CONFIGURATION DIAGRAMS.....	10
4.2 MASTER CONTROL STATION (MCS) INSTALLATION	12
4.3 FULL FUNCTION CREW STATION (FFCS) INSTALLATION	14
4.4 RADIO INTERFACE TERMINAL (RIT) INSTALLATION	16
4.5 MONITOR ONLY STATION (MOS) INSTALLATION	16
4.6 LOUDSPEAKER (LS) INSTALLATION	16
4.7 VIS CABLING INSTALLATION	18
SECTION V. POST-INSTALLATION	22
5.1 POST-INSTALLATION CHECKOUT PROCEDURES	22
5.2 POST-INSTALLATION OPERABILITY VERIFICATION PROCEDURES.....	22
APPENDIX A - REFERENCES	25
A-1. SCOPE.....	25
A-2. FORMS	25
A-3. TECHNICAL MANUALS	25
A-4. MISCELLANEOUS PUBLICATIONS	26

LIST OF TABLES

Number	Title	Page
Table 2-1.	Retained Items List	3
Table 2-2.	Expendable/Durable Items.....	4
Table 2-3.	Tools and Test, Measurement and Diagnostic Equipment.....	4
Table 2-4.	VIS Components (Parts List).....	5
Table 4-1.	MCS Installation Parts	12
Table 4-2.	Commander’s FFCS Installation Parts	14
Table 4-3.	Driver’s FFCS Installation Parts	14

LIST OF FIGURES

Number	Title	Page
Figure 2-1.	Illustrated Parts List	6
Figure 2-2.	Illustrated Parts List - Cables.....	7
Figure 3-1.	FFCS Crew Station Address Switch	9
Figure 4-1.	Equipment Location Diagram	10
Figure 4-2.	System Configuration Diagram.....	11
Figure 4-3.	MCS Installation	13
Figure 4-4.	Commander’s FFCS Installation	15
Figure 4-5.	Driver’s FFCS Installation	15
Figure 4-6.	MCS and Commander’s FFCS Cabling	19
Figure 4-7.	Driver’s FFCS Cabling	21

Section I. INTRODUCTION

1.1 SCOPE

This technical bulletin provides installation instructions for the Intercommunication Set, Vehicular AN/VIC-3(V), hereinafter referred to by its common name, VIS (Vehicular Intercommunication System). There are many current and future variations of this system, e.g. AN/VIC-3(V)1, (V)2, etc., designed for specific vehicles and/or platforms, each with its own unique technical bulletin. The version this technical bulletin covers and the vehicle/platform it is being installed in is:

“AN/VIC-3(V)17”

into the

“GRIZZLY (BREACHER)”

The information contained in this technical bulletin is the official authorization to perform the installation of the VIS at the Unit Maintenance Level.

1.2 GENERAL INFORMATION

a. Reference Publications

There are two manuals associated with the VIS, TM 11-5830-263-10 Operator's Manual, and TM 11-5830-263-20&P Unit Maintenance Manual (Including Repair Parts and Special Tools List (RPSTL)). Additionally, for periodic updated information on the VIS and its specific components refer to the CECOM Supply Bulletin and The Preventive Maintenance Monthly.

b. Purpose of Equipment

The AN/VIC-3(V) or VIS is an intercommunication and radio-control system designed for ground mobile combat vehicles. Digital audio enhances speech quality and intelligibility. Headsets that incorporate active noise reduction (ANR) circuitry increase the effectiveness of vehicle communications. They offer increased hearing protection in the noisy environment of combat vehicles.

c. Equipment Components

The AN/VIC-3(V) or VIS versions are configured for specific vehicles and/or platforms. When installed in a vehicle/platform it loses its identity. VIS is designed to replace the AN/VIC-1 or -2, in some cases utilizing the existing mounting hardware and brackets used by the AN/VIC-1 or -2. VIS consists of LRU's (Line Replaceable Units (Boxes)) (the type and quantity of which vary depending upon the specific vehicle and/or platform), various types of cables (highway, power, alarm, etc.), headsets (the type and quantity of which vary depending upon the specific vehicle and/or platform), brackets, and mounting hardware (nuts, bolts, screws, etc.) for securing both the LRU's and brackets. Every vehicle/platform contains one Master Control Station (MCS), a number of Full Function Crew Stations (FFCS), and a Permanent Magnet Loudspeaker (LS). Depending upon the vehicle/platform VIS is being installed in, it may also contain Radio Interface Terminal(s) (RIT) and Monitor Only Station(s) (MOS).

1.3 CONSOLIDATED INDEX OF ARMY PUBLICATIONS

Refer to the latest issue of DA PAM 25-30 to determine whether there are new editions, changes, or additional publications pertaining to the equipment.

1.4 MAINTENANCE FORMS, RECORDS, AND REPORTS

a. Reports of Maintenance and Unsatisfactory Equipment

Department of the Army forms and procedures used for equipment maintenance will be those prescribed by DA Pam 738-750, as contained in Maintenance Management Update.

b. Reporting of Item and Packaging Deficiencies

Fill out and forward SF364 (Report of Discrepancy (ROD)) as prescribed in AR 735-11-2/DLAR 4140.55/SECNAVINST 4355.18/AFR400-54/MCO 4430.3J.

c. Transportation Discrepancy Report (TDR)(SF361)

Fill out and forward Transportation Discrepancy Report (TDR) (SF361) as prescribed in AR 55-38/NAVSUPINST 4610.33C/AFR 75-18/MCO P4610.19D/DLAR 4500.15.

1.5 CORROSION PREVENTION AND CONTROL

Corrosion Prevention and Control (CPC) of Army materiel is a continuing concern. It is important that any corrosion problems with this item be reported so that the problems can be corrected and improvements can be made to prevent the problem in the future.

While corrosion is typically associated with rusting of metals, it can also include deterioration of other materials, such as rubber and plastic. Unusual cracking, softening, swelling, or breaking of these materials may be a corrosion problem.

If a corrosion problem is identified, it can be reported using SF 368, Product Quality Deficiency Report (QDR). Use of key words such as "corrosion", "rust", "deterioration", or "cracking" will ensure that the information is identified as a CPC problem.

The form should be submitted to the address specified in DA PAM 738-750, Functional User's Manual for the Maintenance Management System (TAMMS).

SECTION II. PREPARATION FOR INSTALLATION

Prior to preparing the vehicle for installation or actually installing the VIS this technical bulletin should be read in its entirety.

2.1 PREPARING THE VEHICLE

- a. To prepare the vehicle for installation, ensure that the site includes adequate lighting. Inspect the vehicle for damage that could effect installation. Have any such damage repaired before installing VIS.

- b. Installing the AN/VIC-3(V) into the vehicle/platform sometimes requires retaining the existing mounting hardware (and brackets) that were used to secure the AN/VIC-1 or -2 systems being replaced. Table 2-1 lists the items, if any, to be retained prior to installation.

Table 2-1. Retained Items List

Item Description and Part Number	Quantity
(None required for this installation)	

2.2 EXPENDABLE/DURABLE ITEMS

Table 2-2 lists the Expendable/Durable items the unit or retrofit/installation team should have on hand prior to the installation of the VIS. Refer to the VIS Operator's TM for specific uses for these items not cited in this technical bulletin.

Table 2-2. Expendable/Durable Items

Item No.	National Stock Number	Description	U/M
1.	6850-00-973-9091	Fluid, Penetrating, (01267) DUOL	CN
2.	7920-00-044-9281	Cloth, Cleaning, (81349), MIL-C-85043	BX
3.	6810-00-292-9625	Degreasing Solvent, (83574) PR-146BLUE	QT
4.	6850-00-664-4959	Silicone Compound, (71984), DC 6	GL
5.	7930-00-282-9699	Detergent, General Purpose, (81349), MIL-D-16791	GL
7.	6810-01-075-5546	Isopropyl Alcohol	CN

2.3 TOOLS AND TEST, MEASUREMENT AND DIAGNOSTIC EQUIPMENT (TMDE)

Table 2-3 lists the tools, and if required, the TMDE needed for installation of the VIS.

Table 2-3. Tools and Test, Measurement and Diagnostic Equipment

NOMENCLATURE	NSN	QUANTITY
Screwdriver, No. 3 Point Phillips, 4 in.	5120-00-234-8912	1
Tool Kit TK101 /G	5180-00-064-5178	1

2.4 VIS COMPONENTS (PARTS LIST)

Table 2-4 lists, with quantities, the Line Replaceable Units (LRU's)(Boxes), Headsets, Cables, Brackets, Mounting Hardware and any other items that will be installed in the vehicle/platform covered by this technical bulletin. This table will be used as a checklist when the pre-installation inventory is conducted. Illustrations (Figures) referenced in Table 2-4 are on the pages immediately following the table. It should be noted that this table does not list parts that need to be retained for reuse from removing the previous AN/VIC-1 or -2 system. Refer to Table 2-1 for those items.

Table 2-4. VIS Components (Parts List)

NSN	ITEM DESCRIPTION AND PART NUMBER	QTY IN VIS	SMR CODE	FIGURE *, ITEM NO.
5895-01-382-3221	Master Control Station (MCS), A3205747	1	PAODD	2-1, 1
5830-01-382-3218	Full Function Crew Station (FFCS), A3205746 (Commander's and Driver's)	2	PAODD	2-1, 2
5965-01-453-2687	Headset, CVC Medium, A3206612-2	2 Total	PAOOO	2-1, 3
5965-01-453-2684	Headset, CVC Large, A3206612-3		PAOOO	2-1, 3
5995-01-406-1171	Cable Assembly, Power, A3206017-10	1	PAOZZ	2-2, 4
5995-01-392-6196	Cable Assembly, Highway, A3206018-2	1	PAOZZ	2-2, 5
5995-01-392-6201	Cable Assembly, Highway, A3206018-16	2	PAOZZ	2-2, 5
5995-01-458-8461	Cable Assembly, R/T, A3206019-10	2	PAOZZ	2-2, 6
5995-01-429-5177	Cable Assembly, Bailout, A3206444	2	PAOZZ	2-2, 7
5995-01-456-8955	Cable Assembly, Bailout, A3207043 (30 ft)	1**	PAOZZ	2-2, 8
5995-01-463-5655	Cable Assembly, Alarm, A3207046	1	PAOZZ	2-2, 9
	Plate, Mounting. A3206395	1	PAOZZ	
5305-00-225-3839	Bolt, Hex Head, MS90725-8	3	PAOZZ	
5305-00-225-9091	Bolt, Hex Head, MS90725-36	6	PAOZZ	
5310-00-880-7746	Nut, Hex 5/16-24. MS51968-5	2	PAOZZ	
5310-00-013-8164	Washer, Lock, MS35335-45	8	PAOZZ	
5310-00-550-1130	Washer, Lock, MS35333-40	3	PAOZZ	
5310-00-081-4219	Washer, Flat, MS27183-12	8	PAOZZ	
	Washer, Flat, MS51412-4A	3	PAOZZ	
5975-00-133-8696	Strap, Tiedown, MS3367-6-9	50***	PAOZZ	
Not applicable	Decal, Reference, A3207047	1	XBOZZ	

* See Figures 2-1 and 2-2 for illustration of the referenced part(s).

** The 30 foot Bailout Cable Assembly is a stowed item.

*** Tie wrap VIS cables to clamped vehicle cables using Tiedown Straps as required.

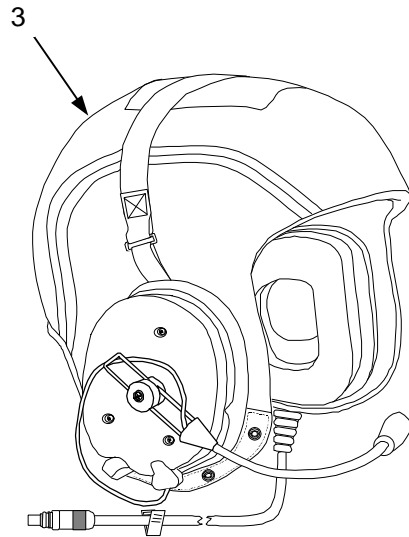
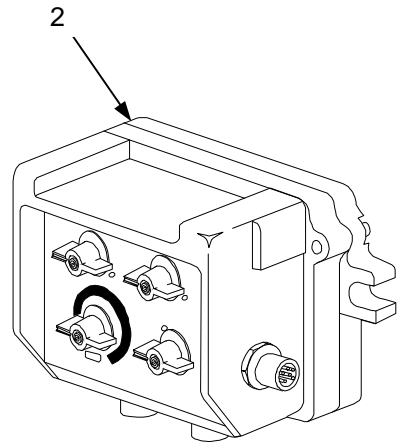
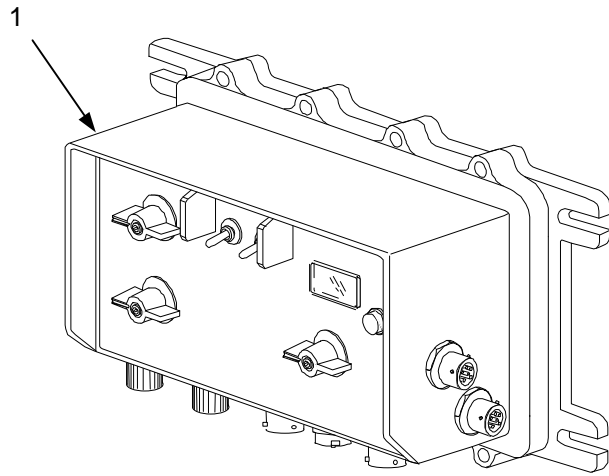

Figure 2-1. Illustrated Parts List

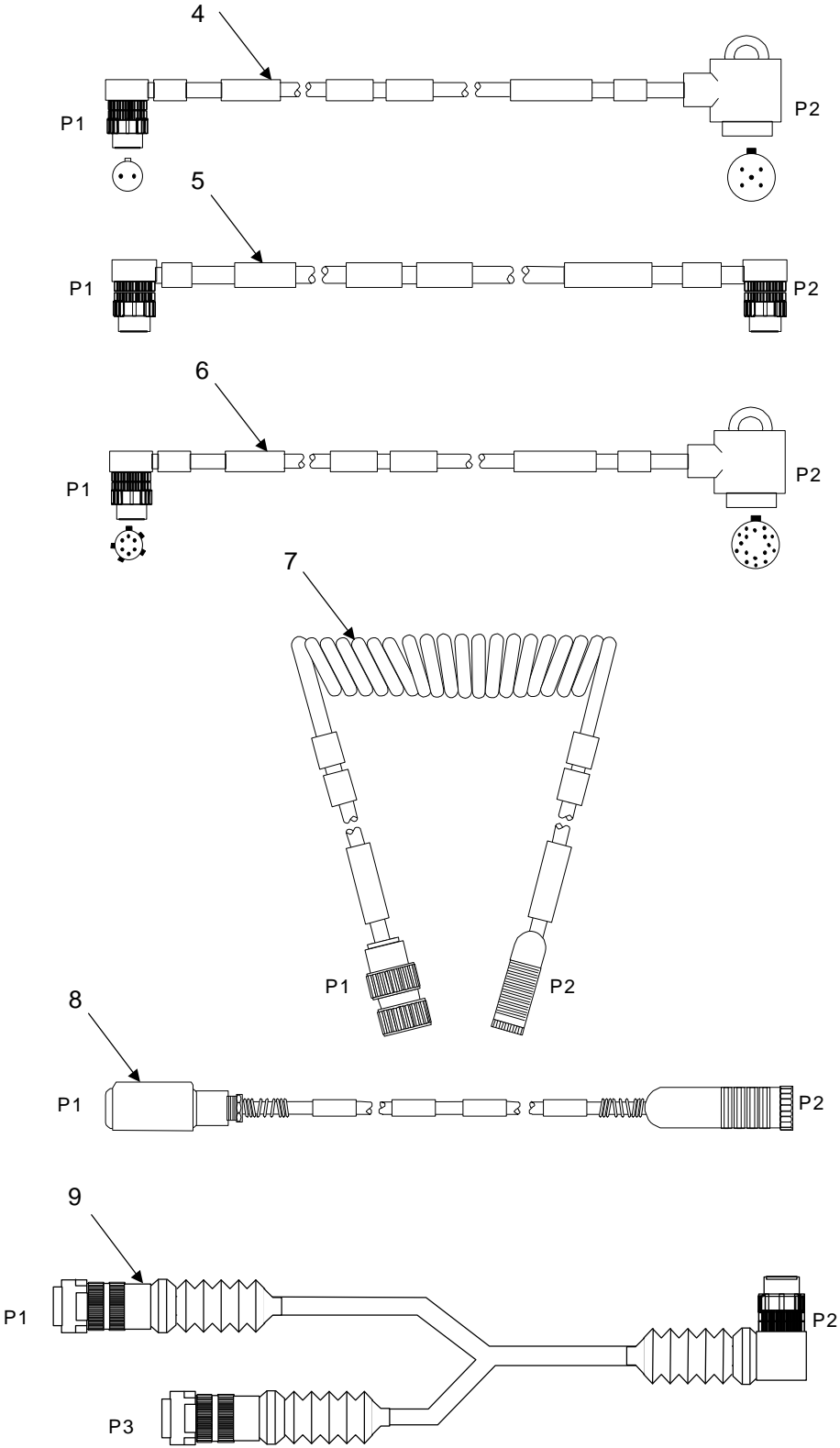

Figure 2-2. Illustrated Parts List - Cables

2.5 PRE-INSTALLATION STEPS AND PROCEDURES

- a. Read the technical bulletin in its entirety prior to performing any designated tasks.
- b. Ensure that the expendable/durable items identified in Table 2-2, and the tools and TMDE, if required, identified in Table 2-3 are available for use.
- c. Remove the AN/VIC-1 or -2 system, if present, in preparation of installing the VIS. Refer to Table 2-1 to determine, what, if any, AN/VIC-1 or -2 components need to be retained.
- d. Unpack VIS equipment/components and conduct a complete physical inventory of the items using Table 2-4 as a checklist. Be sure to inspect packaging for evidence of damage and examine each item for damage. If any discrepancies are noted refer to paragraphs 1.4 and 1.5 for the appropriate maintenance documentation to fill out.
- e. Examine the decal provided with the kit. Identify the number of FFCSs and RIT's. Mark the FFCSs and RITs numerically to match the decal (a piece of tape is recommended).
- f. For each FFCS, set the Crew Station Address Switch to the number marked on it. For each RIT, set the Radio Selection Switch to the appropriate radio setting. Refer to Section III for the appropriate procedures to accomplish these tasks.
- g. You are now ready to install the VIS into the vehicle/platform.

SECTION III. FFCS AND RIT CREW STATION/RADIO SWITCH SETTING PROCEDURES

3.1 FFCS CREW STATION ADDRESS SWITCH SETTING PROCEDURES

Perform the following procedure to change the FFCS Crew Station Address switch setting located on the bottom of the FFCS. Crew Station Addresses are as shown on the Decal.

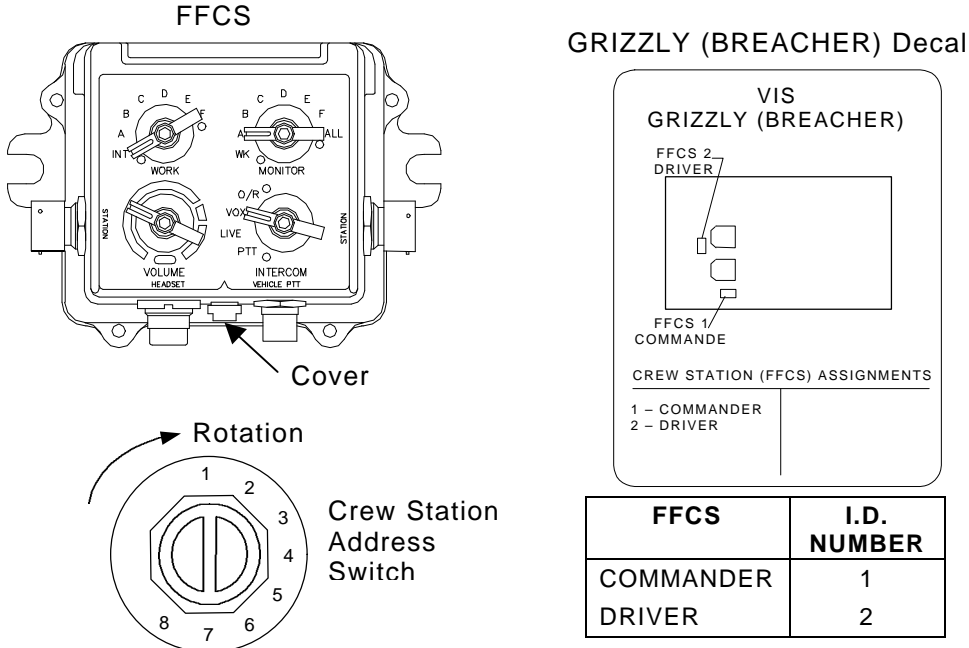

Figure 3-1. FFCS Crew Station Address Switch

- a. Rotate switch cover screw counterclockwise (ccw) and remove.
- b. Using a jeweler’s screwdriver, rotate the adjustment screw ccw, until stop is reached. This is the setting for Crew Station #1.
- c. Each click of the switch in a clockwise direction changes the address by one position. For example, with the switch in the full ccw position (Crew Station #1), turning the switch two clicks in a clockwise direction will set the FFCS to Crew Station #3.
- d. The address switch has 8 positions. Crew Station settings are numbered 1 through 6. Position 7 on the switch is the same as position 6. Position 8 on the switch is normally used for testing, however, if the MCS is not functioning correctly, e.g., loss of timing signal (sync pulse), but is supplying power to the rest of the system, setting the switch to position 8 will result in the FFCS putting out a timing signal like the MCS.
- e. When the correct Crew Station address has been set replace switch cover screw and hand tighten.

3.2 RIT RADIO SELECTION SWITCH SETTING PROCEDURES

This vehicle does not contain any RITs.

SECTION IV. INSTALLATION INSTRUCTIONS

4.1 EQUIPMENT LOCATION AND SYSTEM CONFIGURATION DIAGRAMS

The Equipment Location and the System Configuration Diagrams are shown in Figures 4-1 and 4-2.

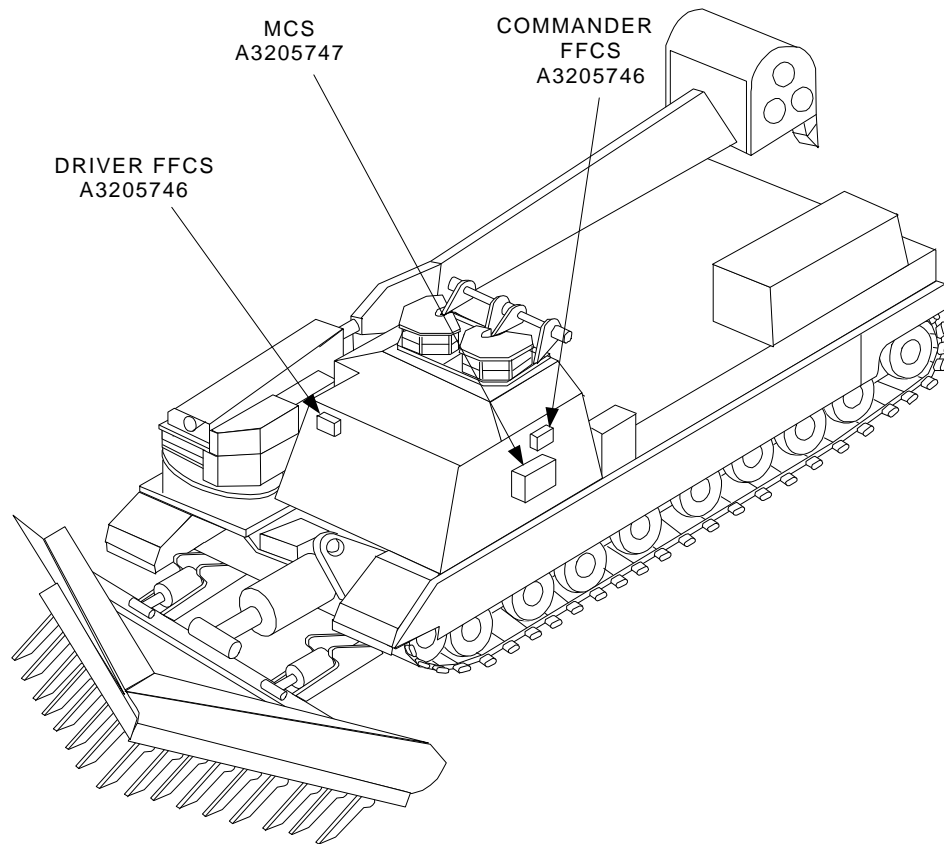
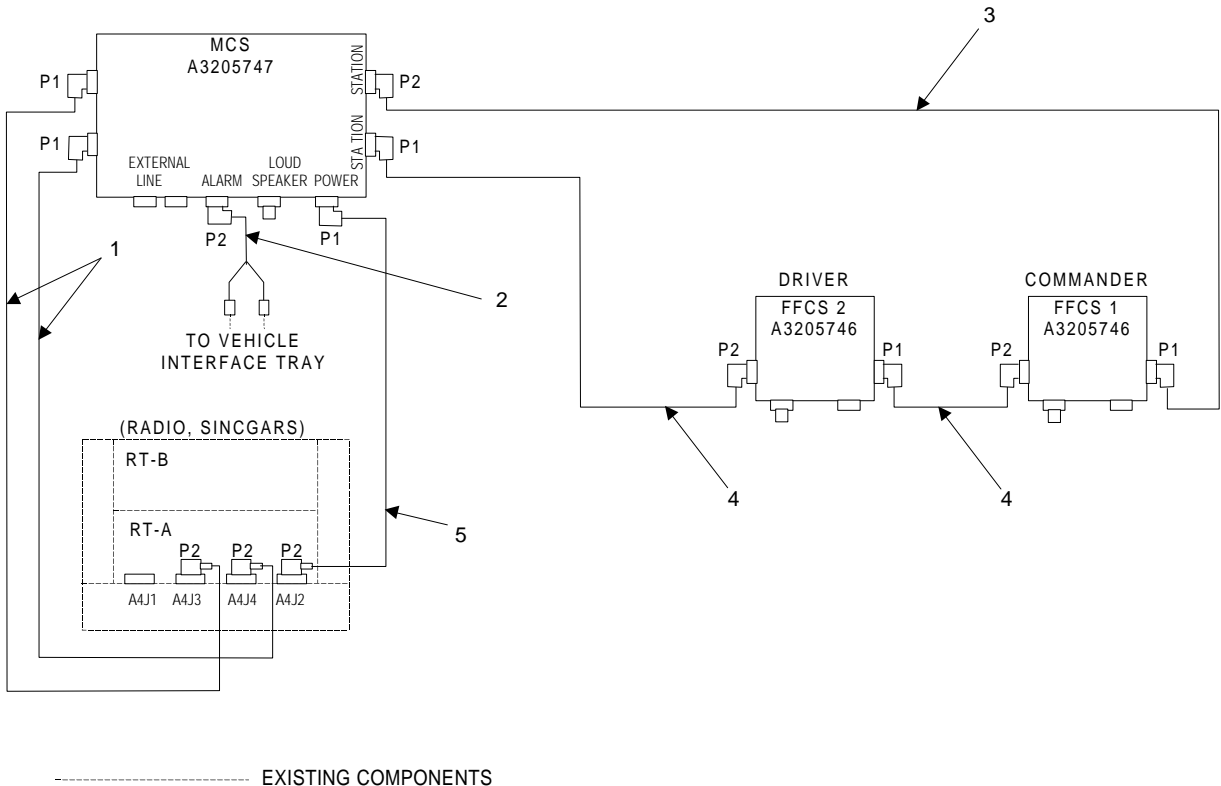

Figure 4-1. Equipment Location Diagram



CABLE PART NUMBERS

- 1. A3206019-10
- 2. A3207046
- 3. A3206018-2
- 4. A3206018-16
- 5. A3206017-10

Cable #	FROM			TO		
	Cable Conn.	Unit	Unit Conn.	Cable Conn.	Unit	Unit Conn.
1	P1	MCS	Radio A	P2	Radio Tray	A4J3
1	P1	MCS	Radio B	P2	Radio Tray	A4J4
2	P2	MCS	Alarm	P1,P3	Vehicle Interface Tray	
5	P1	MCS	Power	P2	Radio Tray	A4J2
3	P2	MCS	Top Station	P1	FFCS #1	Right
4	P2	FFCS #1	Left	P1	FFCS #2	Right
4	P2	FFCS #2	Left	P1	MCS	Bottom Station

Figure 4-2. System Configuration Diagram

4.2 MASTER CONTROL STATION (MCS) INSTALLATION

- a. Install and secure the MCS to the roadside cab wall in the sequence(s) shown in Figure 4-3 using the parts listed in Table 4-1 and the following tools:

1/2 Inch Socket Wrench

- b. Place the Grizzly (Breacher) decal (Item 5), on the cab wall above and to the left of the MCS where it is clearly visible as shown in Figure 4-6.

Table 4-1. MCS Installation Parts

Item No.	Description	Qty	Part Number	NSN
1	MCS	1	A3205747	5895-01-382-3221
2	Bolt, Hex Head	4	MS90725-36	5305-00-225-9091
3	Washer, Lock	4	MS38335-45	5310-00-013-8164
4	Washer, Flat	4	MS27183-12	5310-00-081-4219
5	Decal, Grizzly (Breacher)	1*	A3207047	

* See note 4.2b above.

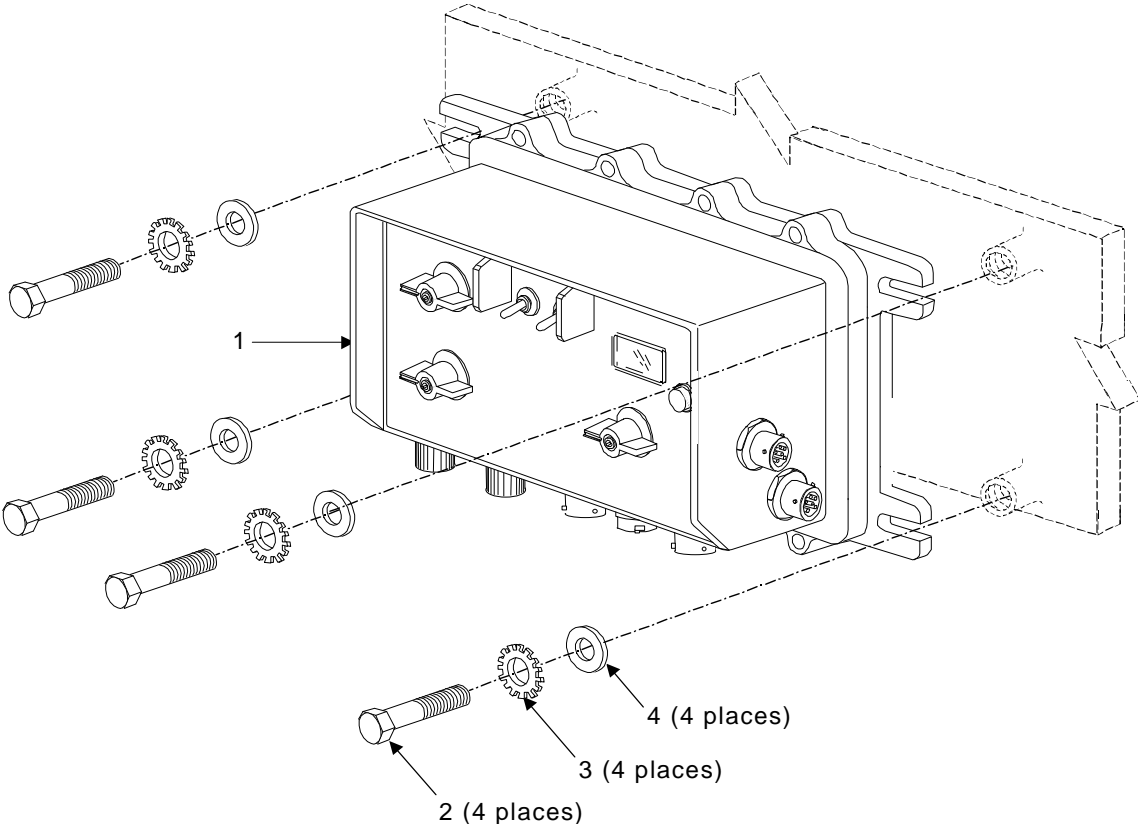

Figure 4-3. MCS Installation

4.3 FULL FUNCTION CREW STATION (FFCS) INSTALLATION

a. Commander's FFCS Installation

Install and secure the Commander's FFCS to the roadside cab wall in the sequence(s) shown in Figure 4-4 using the parts listed in Table 4-2 and the following tools:

1/2 Inch Socket Wrench
7/16 Inch Socket Wrench

Table 4-2. Commander's FFCS Installation Parts

Item #	Description	Qty	Part Number	NSN
1	FFCS	1	A3205746	5830-01-382-3218
2	Nut, Hex 5/16-24	2	MS51968-5	5310-00-880-7746
3	Washer, Lock	2	MS35335-45	5310-00-013-8164
4	Washer, Flat	2	MS27183-12	5310-00-081-4219
5	Plate, Mounting	1	A3206395	
6	Bolt, Hex Head	3	MS90725-8	5305-00-225-3839
7	Washer, Flat	3	MS51412-4A	
8	Washer, Lock	3	MS35333-40	5310-00-550-1130

b. Driver's FFCS Installation

Install and secure the Driver's FFCS to the roadside cab front panel in the sequence(s) shown in Figure 4-5 using the parts listed in Table 4-3 and the following tools:

1/2 Inch Socket Wrench

Table 4-3. Driver's FFCS Installation Parts

Item #	Description	Qty	Part Number	NSN
1	FFCS	1	A3205746	5830-01-382-3218
2	Bolt, Hex Head	2	MS90725-36	5305-00-225-9091
3	Washer, Lock	2	MS35335-45	5310-00-013-8164
4	Washer, Flat	2	MS27183-12	5310-00-081-4219

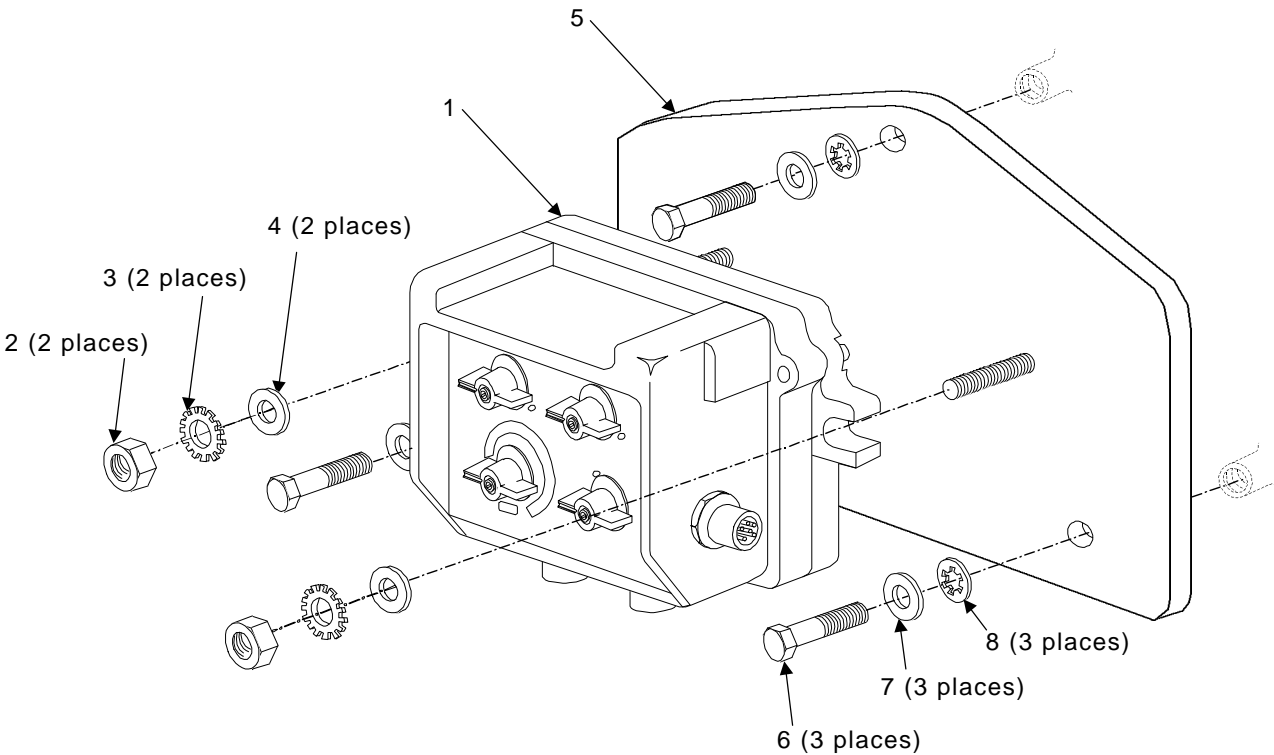

Figure 4-4. Commander's FFCS Installation

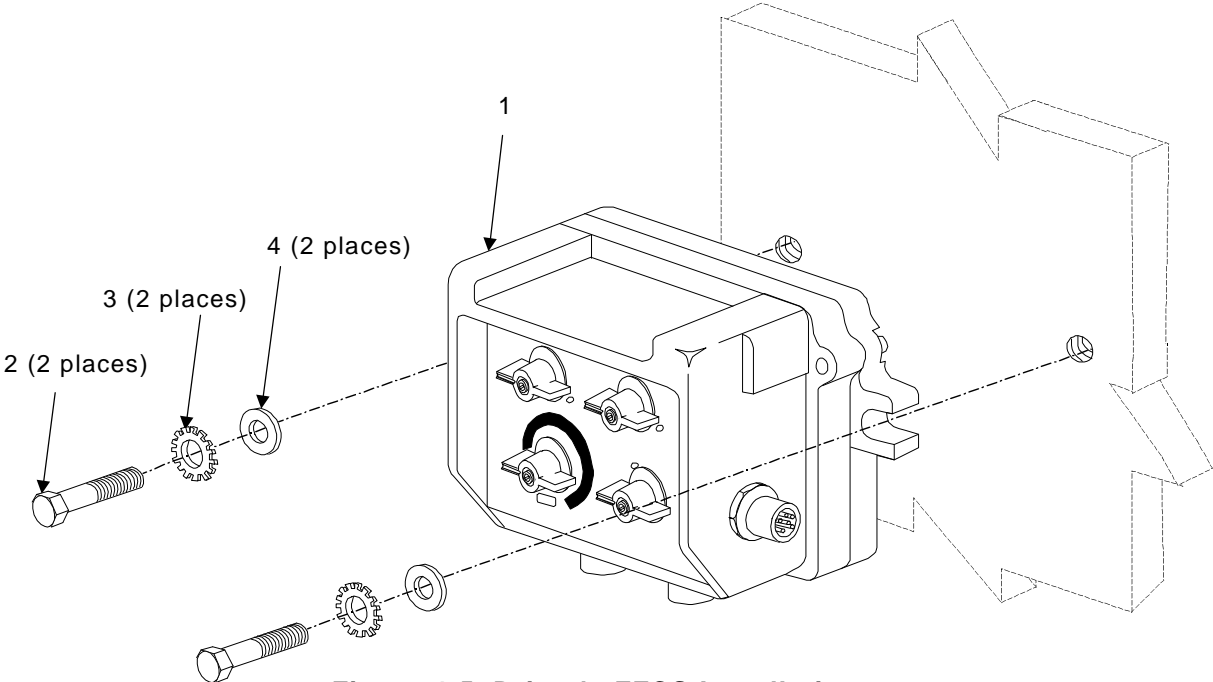

Figure 4-5. Driver's FFCS Installation

4.4 RADIO INTERFACE TERMINAL (RIT) INSTALLATION

This vehicle does not contain any RITs.

4.5 MONITOR ONLY STATION (MOS) INSTALLATION

This vehicle does not contain any MOS'.

4.6 LOUDSPEAKER (LS) INSTALLATION

This vehicle does not contain any Loudspeaker.

4.7 VIS CABLING INSTALLATION

Note

During installation, leave tiedown straps loose enough to adjust cable slack and allow for easy adjustment of equipment. When installation is complete, tighten and secure tiedown straps.

WARNING

MAKE SURE VEHICLE POWER SOURCE IS POSITIONED OFF OR DISCONNECTED BEFORE INSTALLING CABLES.

a. MCS and Commander's FFCS Cabling Installation (Fig. 4-6)

1. Secure connector P1 of the Radio R/T Cable Assembly (5) to the Radio A connector on the MCS (6).
2. Route the Radio R/T Cable (5) along the bulkhead wall, as shown in Figure 4-6, until the Radio Mounting Tray is reached.
3. Secure connector P2 of the Radio R/T Cable Assembly (5) to the Radio Mounting Tray connector A4J3 (see Figure 4-7).
4. Secure connector P1 of the Radio R/T Cable Assembly (5) to the Radio B connector on the MCS (6).
5. Route the Radio R/T Cable (5) along the bulkhead wall, as shown in Figure 4-6, until the Radio Mounting Tray is reached.
6. Secure connector P2 of the Radio R/T Cable Assembly (5) to the Radio Mounting Tray connector A4J4 (see Figure 4-7).
7. Secure connector P1 of the Power Cable Assembly (3) to the Power connector on the MCS (6).
8. Route the Power Cable Assembly (3) along the bulkhead wall as shown in Figure 4-6, until the Radio Mounting Tray is reached.
9. Secure connector P2 of the Power Cable Assembly (3) to the Radio Mounting Tray connector A4J2 (see Figure 4-7).
10. Secure Connector P2 of Alarm Cable Assembly (4) to the Alarm connector on the MCS (6).
11. Route the Alarm Cable Assembly (4) along the bulkhead wall as shown in Figure 4-6 until the Vehicle Interface Tray is reached.
12. Secure connectors P1 and P3 of Alarm Cable Assembly (4) to the appropriate connectors on the Vehicle Interface Tray.
13. Secure connector P1 of the Highway Cable Assembly (2) to the bottom Station connector on the MCS (6).
14. Route the Highway Cable Assembly (2) along the bulkhead wall, as shown in Figure 4-6, until the Driver's FFCS (Figure 4-7) is reached.
15. Secure connector P2 of the Highway Cable Assembly (1) to the top Station connector on the MCS (6).
16. Route the Highway Cable Assembly (1) along the bulkhead wall as shown in Figure 4-6, until the Commander's FFCS (7) is reached.
17. Secure connector P1 of the Highway Cable Assembly (1) to the right side Station connector of the Commander's FFCS (7).

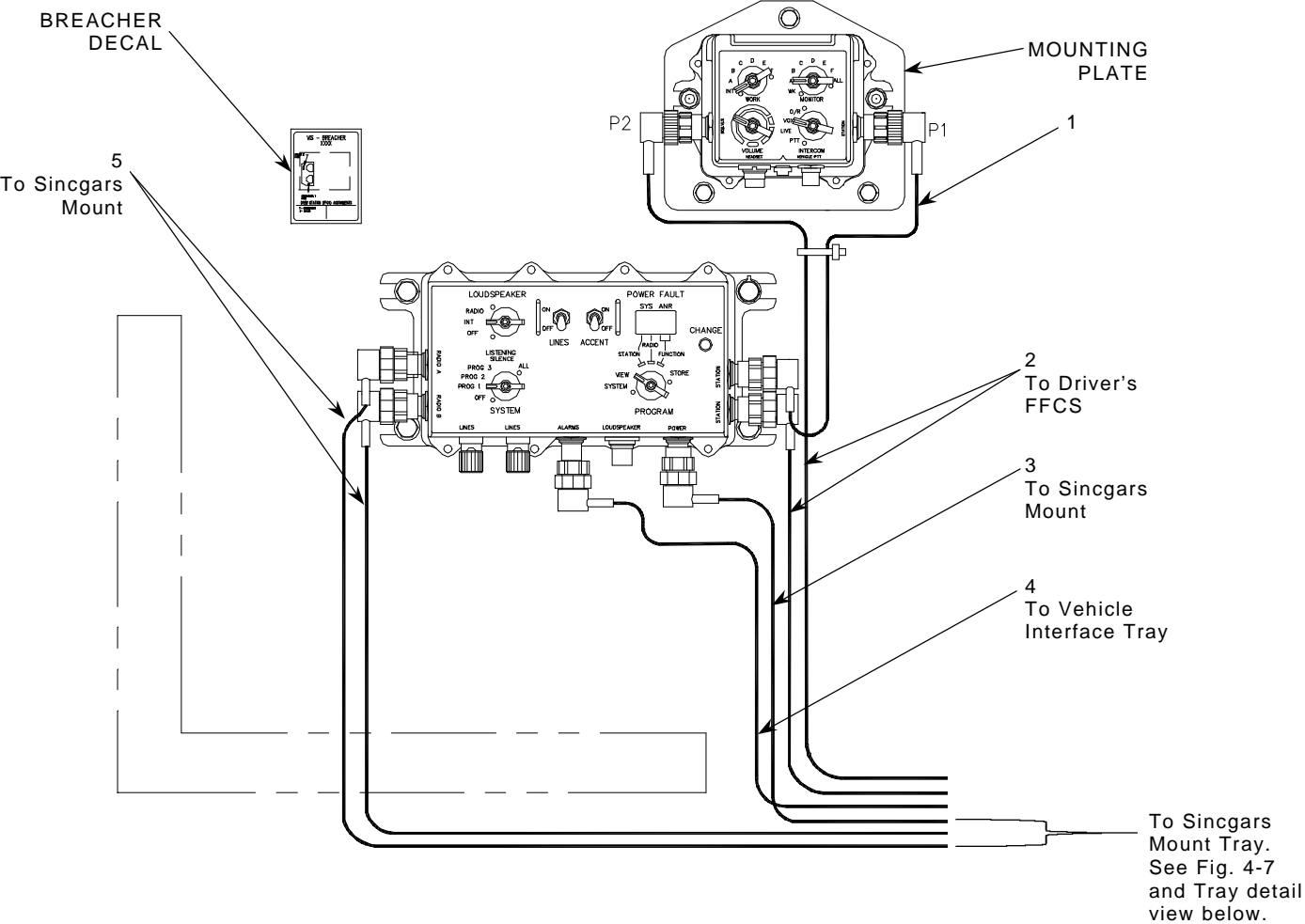

ROADSIDE CAB WALL, COMMANDER'S STATION

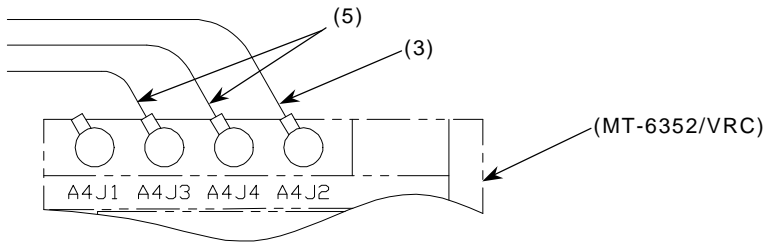

SINGGARS MOUNT TRAY DETAIL

- 1. Highway Cable Assembly (A3206018-2)
- 2. Highway Cable Assembly (A3206018-16)
- 3. Power Cable Assembly (A3206017-10)
- 4. Alarm Cable Assembly (A3207046)
- 5. Radio R/T Cable Assembly (A3206019-10)
- 6. MCS
- 7. Commander's FFCS

Figure 4-6. MCS and Commander's FFCS Cabling

4.7 VIS CABLING INSTALLATION (continued)

b. Driver's FFCS Cabling Installation (Fig. 4-7)

1. Secure connector P2 of the Highway Cable Assembly (1), from the MCS, to the left side Station connector of the Driver's FFCS (2).
2. Secure connector P1 of the Highway Cable Assembly (1), from the Commander's FFCS, to the right side Station connector of the Driver's FFCS (2).

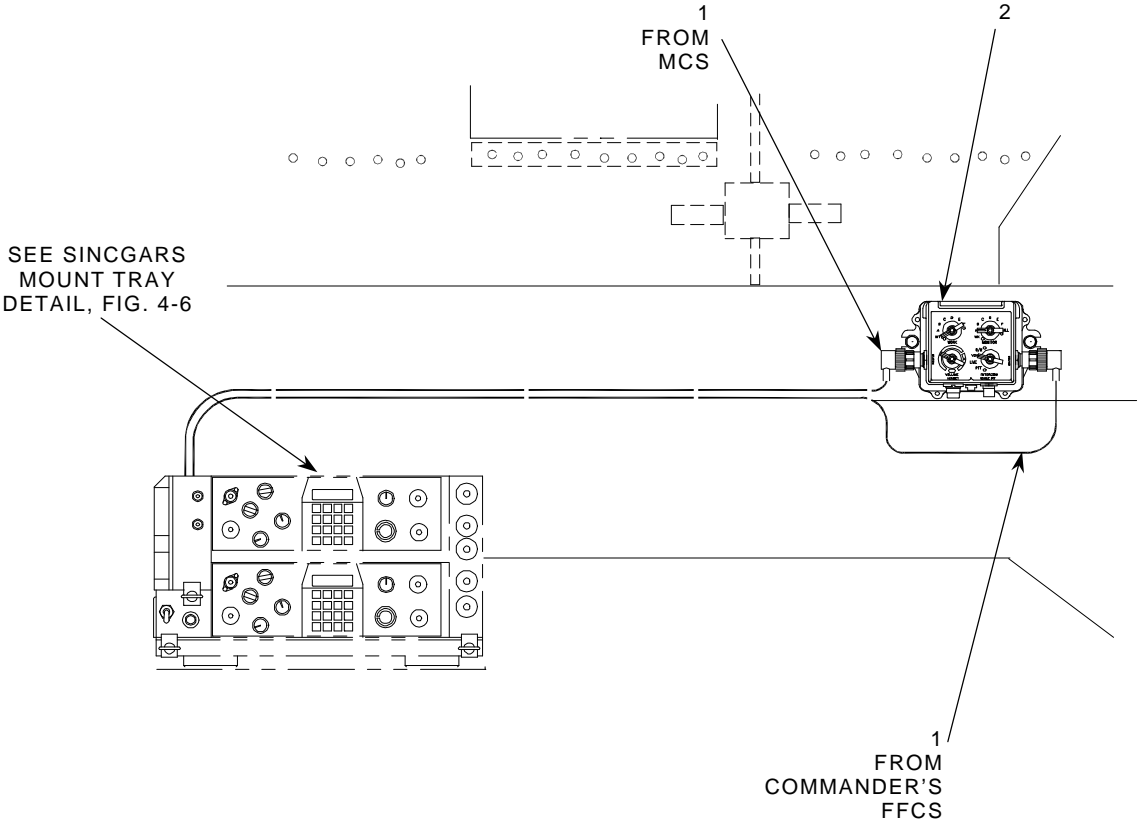

ROADSIDE CAB, AT DRIVER'S STATION

- 1. Highway Cable Assembly (A3206018-16)
- 2. Driver's FFCS

Figure 4-7. Driver's FFCS Cabling

SECTION V. POST-INSTALLATION

5.1 POST-INSTALLATION CHECKOUT PROCEDURES

- a. Check that all LRU's are securely mounted.
- b. Verify that all cables are securely and correctly fastened and routed properly. Refer to Figure 4-2, System Configuration Diagram if needed.
- c. Tighten all tiedown straps and ensure that there is enough slack in the cables to allow for ease in disconnecting and connecting from the LRU's.
- d. Apply a small amount of silicone grease to the O-Ring in the bailout cable connector of the headset. Connect bailout cables to the bailout connectors of the vehicle headsets. Connect bailout cables to the HEADSET connector on the FFCS', and MOS' if present.

5.2 POST-INSTALLATION OPERABILITY VERIFICATION PROCEDURES

Note

The following steps are simple go; no-go procedures to ensure that communication can be accomplished utilizing the LRU's and headsets. For actual programming instructions and for more thorough operating procedures refer to the VIS Operator's Technical Manual.

a. Setting the System Configuration on the MCS

1. On the MCS, set and hold the **PROGRAM** switch in the **STORE** position. While holding the **PROGRAM** switch in the **STORE** position depress and hold the **CHANGE** button.
2. While holding the **PROGRAM** switch in the **STORE** position and depressing the **CHANGE** button, set the **SYSTEM** switch in the **ALL** position.
3. Observe the display as it cycles through "****", "**Pr15**", "**v07**" and "**cfg**". When "**cfg**" appears on the display release the **PROGRAM** switch and **CHANGE** button.
4. The display will show the system configuration, e.g. what FFCS' (1,2,3,4,5,6) and RITs (C/D, E/F) are connected as well as if the ring is connected.

Note

Observing the display while the system configuration is being conducted allows the operator to cross check if the FFCS' and RIT's identification switch settings are correct. If there are four FFCS', with the address switch settings of 1 through 4, then the display should show "1c", "2c", "3c", and "4c". If a RIT or RITs are connected the display should show "Cc" or "Cc", "Dc", "Ec" and "Fc".

5. When system configuration has been completed, the display will show "**done**", immediately followed by "**Avhf**" with the "**vhf**" portion blinking. Holding the **PROGRAM** switch momentarily in the **STORE** position will

program “**Avhf**” into the system configuration memory. Upon releasing the **PROGRAM** switch “**done**” will again appear on the display. “**Bvhf**” will then appear on the display with the “**vhf**” portion blinking.

6. Repeat the process for holding the **PROGRAM** switch momentarily in the **STORE** position for “**Bvhf**”. If a RIT or RITs are connected, “**Cvhf**”, “**Dvhf**”, etc.; will also appear on the display. Simply repeat the process used for storing “**Avhf**” and “**Bvhf**” to the system configuration memory.
7. After the radios are stored in the system configuration memory the display will show “**test**”, “**pass**”, then “**ALL**”. At this time turn the MCS **SYSTEM** switch to **OFF**.

b. FFCS and Headset Operability

Note

Checking the operability of the FFCS' and Headsets requires two people.

1. Set the MCS **PROGRAM** switch on **SYSTEM** and the **SYSTEM** switch on **PROG 1**.
2. The system will initialize then start conducting Built-In-Test (BIT). The display will show “**test**” while BIT is being conducted.
3. If there are no configuration discrepancies or errors, the display shows “**pass**” followed immediately by the system mode “**P1**”. If there are configuration discrepancies or errors, the display will show “**fail**”, followed by error codes. If the display does show “**fail**” followed by the error codes, refer to the VIS Operator's Manual and/or Unit Maintenance Manual for troubleshooting and repair procedures.
4. Go to the first two FFCS' and put on the headsets connected to them. For both FFCS's, place the **WORK** switch on **INT**, the **MONITOR** switch on **WK**, and the **INTERCOM** switch on **PTT**.

Note

For the full procedures on FFCS, MOS, and Headset operations refer to the VIS Operator's Manual.

5. Communicate on the intercom by activating the headset or vehicle PTT switch. After intercom communication has been established, cycle through the **LIVE**, **VOX** and **O/R** functions of the FFCS **INTERCOM** switch as well as testing the operability of the Active Noise Reduction (ANR) switch (if present) and the PTT switch on the headsets.
6. Repeat these actions for all remaining FFCS' and Headsets, and MOS' if present. Additionally, test the Loudspeaker by placing the MCS **LOUDSPEAKER** switch on **INT** and communicating.
7. Upon completion of these procedures turn the MCS **SYSTEM** switch to **OFF**. The post-installation operability verification procedures are complete.

APPENDIX A - REFERENCES

A-1. SCOPE

This appendix lists forms, technical manuals, and miscellaneous publications that are either referenced in this technical bulletin or may be of use in installing and/or operating the Vehicular Intercommunication System (VIS).

A-2. FORMS

DA Form 2028-2	Recommended Changes to Equipment Technical Publications
SF 361	Discrepancy in Shipment Report (DISREP)
SF 364	Report of Discrepancy (ROD)
SF 368	Product Quality Deficiency Report (QDR)

A-3. TECHNICAL MANUALS

TM 11-5805-201-12	Operator's and Unit Maintenance Manual for Telephone Sets, TA-312/PT and TA-312A/PT
TM 11-5820-401-10-1	Operator's Manual for Radio Sets AN/VRC-12, AN/VRC-43, AN/VRC-44, AN/VRC-45, AN/VRC-46, AN/VRC-47, AN/VRC-48, and AN/VRC-49 (used without Intercom Systems)
TM 11-5820-401-10-2	Operator's Manual for Radio Sets, AN/VRC-12, AN/VRC-43, AN/VRC-44, AN/VRC-45, AN/VRC-46, AN/VRC-47, AN/VRC-48, and AN/VRC-49 (used with Intercom Systems)
TM 11-5820-401-20-1	Organizational Maintenance for Radio Sets, AN/VRC-12, AN/VRC-43, AN/VRC-44, AN/VRC-45, AN/VRC-46, AN/VRC-47, AN/VRC-48, and AN/VRC-49(used w/o Intercom Set)
TM 11-5820-401-20-2	Organizational Maintenance Manual for Radio Sets, AN/VRC-12, AN/VRC-43, AN/VRC-44, AN/VRC-45, AN/VRC-46, AN/VRC-47, AN/VRC-48, and AN/VRC-49 (used with Intercom Set AN/VIC-1(V))
TM 11-5820-890-10-3	Operator's Manual for Singars Ground Combat Net Radio, Non-ICOM Manpack Radio AN/PRC-119, Short Range Vehicular Radio AN/VRC-87, Short Range Vehicular Radio (with Radio Mount) AN/VRC-87D, Short Range Vehicular Radio with Dismount AN/VRC-88, Short Range Vehicular Radio with Dismount (with Single Radio Mount) AN/VRC-88D, Short Range/Long Range Vehicular Radio AN/VRC-89, Long Range Vehicular Radio AN/VRC-90, Short Range/Long Range Vehicular Radio With Dismount AN/VRC-91, Long Range/Long Range Vehicular Radio AN/VRC-92

TB 11-5830-263-20-17

TM 11-5820-890-10-8	Operator's Manual for Sincgars Ground Combat Net Radio, ICOM Manpack Radio, AN/PRC-119A, Short Range Vehicular Radio AN/VRC-87A, Short Range Vehicular Radio with Dismount AN/VRC-88A, Short Range/Long Range Vehicular Radio AN/VRC-88C, Short Range/Long Range Vehicular Radio AN/VRC-89A, Long Range Vehicular Radio AN/VRC-90A, Short Range/Long Range Vehicular Radio with Dismount AN/VRC-91A, Short Range/Long Range Vehicular Radio AN/VRC-92A used with Automated Net Control Device (ANCD)(AN-CYZ-10), Precision Lightweight GPS Receiver (PLGR)(AN/PSN-11) Secure Telephone Unit(STU) Frequency Hopping Multiplexer(FHMUX)
TM 11-5820-890-20-1	Unit Maintenance Manual for Ground ICOM Radio Sets AN/PRC-119A, AN/VRC-87A, AN/VRC-88A, AN/VRC-89A, AN/VRC-90A, AN/VRC-91A, AN/VRC-92A
TM 11-5820-890-20-2	Unit Maintenance Manual for Ground ICOM Radio Sets AN/PRC-119A, AN/VRC-87A, AN/VRC-87C, AN/VRC-88A, AN/VRC-89A, AN/VRC-90A, AN/VRC-91A, AN/VRC-92A (with Control, Receiver-Transmitter C-11561(C)/U(RCU))
TM 11-5820-890-20-3	Unit Level Maintenance Handbook Sincgars ICOM Ground Radios for Ground ICOM Radio Sets AN/PRC-119A, AN/VRC-87A, AN/VRC-88A, AN/VRC-89A, AN/VRC-90A, AN/VRC-91A, AN/VRC-92A
TM 11-5820-890-20-4	
TM 11-5820-923-12	Operator's and Organizational Maintenance Manual for Radio Set, AN/GRC-213
TM 11-5830-263-10	Operator's Manual for Vehicular Intercommunication Set AN/VIC-3(V)
TM 11-5830-263-20&P	Unit Maintenance Manual for Intercommunication Set, Vehicular AN/VIC-3(V)
TM 11-5830-340-12	Operator's and Unit Organizational Maintenance Manual for Intercommunication Set, AN/VIC-1(V) and Control, Intercommunication Set, C-10456/VRC
TM 746-10	General Packaging Instructions for Field Units
TM 750-244-2	Procedure for Destruction of Electronics Material to Prevent Enemy Use (Electronics Command)

A-4. MISCELLANEOUS PUBLICATIONS

AMDF	Army Master Data File(Microfiche)
AR 55-38	Transportation Deficiency Report (TDR)
AR 380-5	Department of the Army Information Security Program
AR 710-2	Inventory Management Supply Policy Below the Wholesale Level
AR 725-50	Requisition, Receipt and Issue System
AR 735-11-2	Reporting of Item and Packaging Discrepancies

A-4. MISCELLANEOUS PUBLICATIONS (continued)

DA PAM 25-30	Consolidated Index of Army Publications (Microfiche)
DA PAM 710-2-1	Using Unit Supply System Manual Procedures as Contained in Unit Supply UPDATE
DA PAM 738-750	Maintenance Management Update
SB 11-131-2	Vehicular Radio Sets and Authorized Installations Volume II (Sincgars, FHMUX, and EPLRS)
SB 11-573	Painting and Preservation of Supplies Available for Field Use for Electronics Command Equipment



THEN . JOT DOWN THE INFO
ABOUT IT ON THIS FORM.
CAREFULLY TEAR IT OUT.
FOLD IT AND DROP IT IN THE
MAIL.

SOMETHING WRONG WITH THIS PUBLICATION

FROM: (PRINT YOUR UNITS COMPLETE ADDRESS)
Commander
Stateside Army Depot
A-I-I-N: AMSTA-US
Stateside, N.J. 07703-5007

DATE SENT
10 July 1975

PUBLICATION NUMBER
TM 11-5840-340-12

PUBLICATION DATE
23 Jan 74

PUBLICATION TITLE
Radar Set AN/PRC-76

BE EXACT PIN-POINT WHERE IT IS

IN THIS SPACE TELL WHAT IS WRONG
AND WHAT SHOULD BE DONE ABOUT IT:

PAGE NO	PARA GRAPH	FIGURE NO	TABLE NO
---------	------------	-----------	----------

2-25

2-28

Recommend that the installation antenna alignment procedure be changed throughout to specify a 20 IFF antenna lag rather than 10.

REASON: Experience has shown that with only a 10 lag, the antenna servo system is too sensitive to wind gusting in excess of 25 knots, and has a tendency to rapidly accelerate and decelerate as it hunts, causing stress to the drive train. Hunting is minimized by adjusting the lag to 20 without degradation of operation.

3-10

3-3

3-1

Item 5, Functional Test Plan. Change \square 2 dB" to \square 3 dB".

REASON: The adjustment procedure for the TRANS POWER FAULT indicator calls for a 3 dB (500 watts) adjustment to light the TRANS POWER FAULT indicator.

5-6

5-8

Change new step f.1 to read, \square Replace cover plate removed in step above."

REASON: To replace the cover plate.

FO-3

Zone C 3. On J1-2, change \square +24 VDC" to \square +5 VDC".

REASON: This is the output line of the 5 VDC power supply. +24 VDC is the input voltage.

TEAR ALONG DOTTED LINE

PRINTED NAME, GRADE OR TITLE AND TELEPHONE NUMBER

SSG I. M. DeSpirito 999-1776

SIGN HERE

FILL IN YOUR
UNIT'S ADDRESS

FOLD BACK

DEPARTMENT OF THE ARMY



OFFICIAL BUSINESS

PLEASE
AFFIX
STAMP
POSTAGE
REQUIRED

SAMPLE

Commander
U.S. Army Communications-Electronics Command
and Fort Monmouth
ATTN: AMSEL-LEO-D-CS-CFO
Fort Monmouth, New Jersey 07703-5000

TEAR ALONG DOTTED LINE



SOMETHING WRONG WITH THIS PUBLICATION

*THEN . JOT DOWN THE INFO
ABOUT IT ON THIS FORM
CAREFULLY TEAR IT OUT
FOLD IT AND DROP IT IN THE
MAIL.*

FROM: (PRINT YOUR UNIT'S COMPLETE ADDRESS)

DATE SENT

PUBLICATION NUMBER

PUBLICATION DATE

PUBLICATION TITLE

BE EXACT PIN-POINT WHERE IT IS

IN THIS SPACE TELL WHAT IS WRONG
AND WHAT SHOULD BE DONE ABOUT IT:

PAGE
NO

PARA
GRAPH

FIGURE
NO

TABLE
NO

TEAR ALONG DOTTED LINE

PRINTED NAME, GRADE OR TITLE AND TELEPHONE NUMBER

SIGN HERE

FILL IN YOUR
UNIT'S ADDRESS

FOLD BACK

DEPARTMENT OF THE ARMY

OFFICIAL BUSINESS

PLEASE
AFFIX
STAMP
POSTAGE
REQUIRED

TEAR ALONG DOTTED LINE

**Commander
U.S. Army Communications-Electronics Command
and Fort Monmouth
ATTN: AMSEL-LC-LEO-D-CS-CFO
Fort Monmouth, New Jersey 07703-5000**

SOMETHING WRONG WITH THIS PUBLICATION



THEN . JOT DOWN THE INFO ABOUT IT ON THIS FORM. CAREFULLY TEAR IT OUT. FOLD IT AND DROP IT IN THE MAIL.

FROM: (PRINT YOUR UNIT'S COMPLETE ADDRESS)

DATE SENT

PUBLICATION NUMBER

PUBLICATION DATE

PUBLICATION TITLE

BE EXACT PM-POINT WHERE IT IS

IN THIS SPACE TELL WHAT IS WRONG AND WHAT SHOULD BE DONE ABOUT IT:

PAGE NO

PARA GRAPH

FIGURE NO

TABLE NO

TEAR ALONG DOTTED LINE

PRINTED NAME, GRADE OR TITLE AND TELEPHONE NUMBER

SIGN HERE

FILL IN YOUR
UNIT'S ADDRESS

FOLD BACK

DEPARTMENT OF THE ARMY

OFFICIAL BUSINESS

PLEASE
AFFIX
STAMP
POSTAGE
REQUIRED

TEAR ALONG DOTTED LINE

Commander
U.S. Army Communications-Electronics Command
and Fort Monmouth
ATTN: AMSEL-LC-LEO-D-CS-CFO
Fort Monmouth, New Jersey 07703-5000

SOMETHING WRONG WITH THIS PUBLICATION



THEN... JOT DOWN THE INFO ABOUT IT ON THIS FORM. CAREFULLY TEAR IT OUT. FOLD IT AND DROP IT IN THE MAIL.

FROM: (PRINT YOUR UNIT'S COMPLETE ADDRESS)

DATE SENT

PUBLICATION NUMBER

PUBLICATION DATE

PUBLICATION TITLE

I

BE EXACT PIN-POINT WHERE IT IS

IN THIS SPACE TELL WHAT IS WRONG AND WHAT SHOULD BE DONE ABOUT IT:

PAGE NO

PARA GRAPH

FIGURE NO

TABLE NO

TEAR ALONG DOTTED LINE

PRINTED NAME, GRADE OR TITLE AND TELEPHONE NUMBER

SIGN HERE

FILL IN YOUR
UNIT'S ADDRESS

FOLD BACK

DEPARTMENT OF THE ARMY

PLEASE
AFFIX
STAMP
POSTAGE
REQUIRED

OFFICIAL BUSINESS

**Commander
U.S. Army Communications-Electronics Command
and Fort Monmouth
ATTN: AMSEL-LC-LEO-D-CS-CFO
Fort Monmouth, New Jersey 07703-5000**

TEAR ALONG DOTTED LINE

By Order of the Secretary of the Army:

Official:

JOEL B. HUDSON
*Administrative Assistant to the
Secretary of the Army*
0008311

ERIC K. SHINSEKI
*General, United States Army
Chief of Staff*

DISTRIBUTION:

To be distributed in accordance with the initial distribution number (IDN) 361382 requirements for TB 11-5830-263-20-17.

